

### MONIXO® FluidMiner

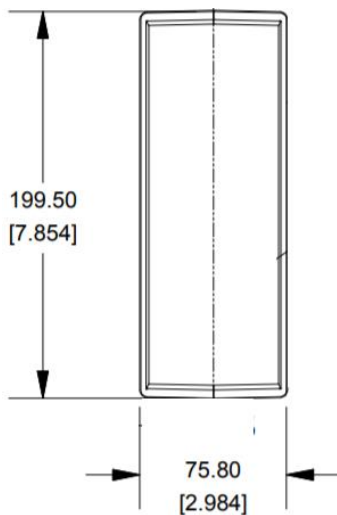

PATENTED



For questions or support, please contact  
Monixo  
Support Email: [contact@monixo.com](mailto:contact@monixo.com)

We reserve all rights in this document and in  
the information contained therein.  
Reproduction, use, or disclosure to third  
parties without express authority is strictly  
forbidden.

Specifications	Remarks
<b>fluidMiner</b>	
Capacity	4 measurements
Embedded measurements	Temperature , pH, concentration, conductivity, solid particles, bacteria, viscosity
<b>pH measurement</b>	
Accuracy	±0,01
Measurement Range	[0 – 14]
<b>Concentration measurement</b>	
Measurement Range	[0% - 80%] Brix
Accuracy	0,05%
<b>Temperature measurement</b>	
Measurement Range	[5°C – 80°C]
<b>Local wireless communication (narrow band)</b>	
Banwidth	868 Mhz
Direction	Bidirectionnal
Modulation	FSK(frequency-shift keying )
Power level	+5dBm
Sensitivity	-110dBm
Outdoor range (maximum)	1000m
indoor range (maximum)	400m
Maximum bit rate	1,2kbps
Frequency deviation	45KHz
Reception bandwidth	67KHz
Automatic Frequency Control (AFC)	Activated
Error detection	CRC
Encryption	Activated
Message Protocol	MQTT
<b>Network transmission</b>	
Standards	Mobile Network to Web and mobile application
<b>Power</b>	
Power consumption	110W
Voltage	110 -220 V
<b>Standards</b>	
	FCC & ETSI
<b>Physical</b>	
Material	ABS (Case) , Silicone (pipe)